



Residential / Commercial Gas Tankless Water Heaters



Tankless Non-Condensing Models

DESIGNED FOR PERFORMANCE

- Maximum flow rates up to 10.0 GPM
- Available in natural gas (NG) or propane (LP)
- Models include both a remote control and power cord as standard features
- Low NOx emissions
- Complies with lead free standards
- Heat exchanger is constructed of stainless steel
- Built-in freeze protection
- Air-fuel ratio (AFR) sensor
- Electronic ignition

KEEPING YOU SAFE

- Manual reset hi limit (set at 194°F)
- Overheat cutoff fuse
- Inlet and outlet thermistors for constant temperature monitoring
- Flame sensor

OPTIONAL ACCESSORIES

- Complete line of Category III venting
- Direct vent conversion kits (TK-TV10)
- Isolation valve kits (TM-IV01-AB)
- Backflow preventer (2SVBFDPA04)
- Concentric direct vent kit (2SVSHTCKIT43)
- Pipe cover (TK-PC01)

LIMITED WARRANTY

- 15-year limited warranty on heat exchanger in residential applications
- 5-year limited warranty on all parts



GSWT-310



ANSI Z21.10.3 CSA 4.3



Residential / Commercial Gas Tankless Water Heaters



SPECIFICATIONS

Model	Fuel Type	Gas Consumption Input		Inlet Gas Pressure		Energy Factor	Flow Rate*		Hot and Cold Gas Connection	Dimensions IN (CM)			Unit Weight LB (KG)
		Min. BTU/h	Max. BTU/h	Min. W.C.	Max. W.C.		@30°F Rise	@70°F Rise		Height	Width	Depth	
GSWT-310-N	Natural	11,000	190,000	5.0	10.5	0.82	8	4.3	¾" NPT	20 ¼ (52)	13 ¾ (35)	9 ½ (24)	38 (17)
GSWT-310-P	Propane	11,000	190,000	8.0	14.0	0.82	8	4.3	¾" NPT	20 ¼ (52)	13 ¾ (35)	9 ½ (24)	38 (17)

15-150 PSI water pressure. 40 PSI or above recommended for maximum flow.

*Current numbers based on factory testing, 0.5 GPM required for activation, 0.4 GPM required for continuous fire after initial ignition.

Models are certified from sea level to 6,000 ft. (1,829 m) elevation.

GSWT-310 DIMENSIONS

MINIMUM CLEARANCES: TOP 12", BOTTOM 12", FRONT* 4", BACK 1", SIDES 3"

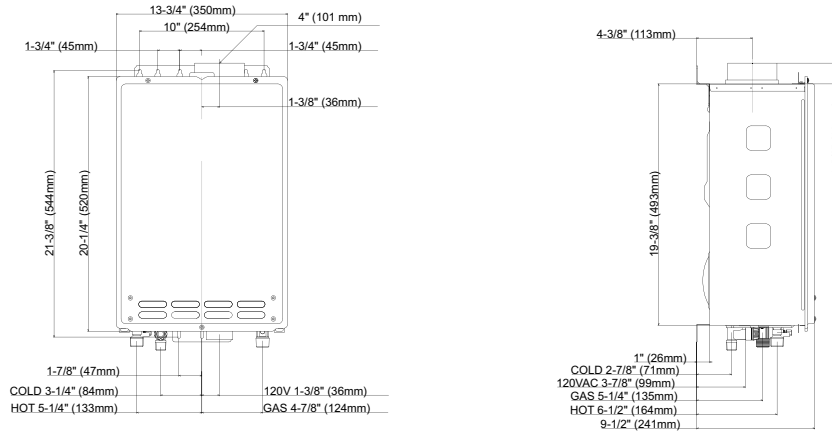

*Recommended 24" clearance from front of unit for maintenance

310 Pressure Loss

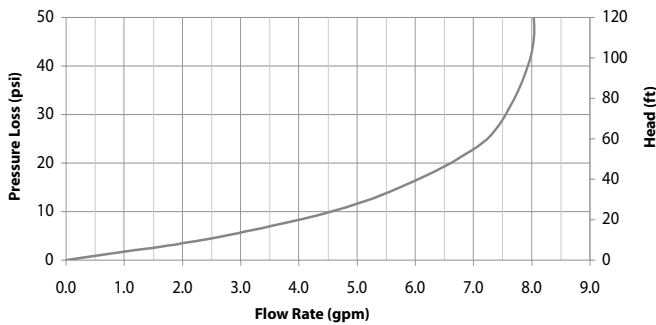

Comparison of Flow Rates vs. Temperature Rise

